

What You Need To Know About Nitrogen Piping

Introduction

The transfer of liquid cryogenics over any distance in a plant, whether indoors or outdoors, requires special piping. The issues that need to be considered in any type of cryogenic liquid transfer piping system are as follows:

Loss of cryogen through evaporation

Quality of cryogen delivery to point of use

HEAT LEAKS AFFECT PERFORMANCE

Increased heat leaks in the transfer system result in excessive gas in the system which causes:

1. Diminished cooling capacity
2. Excessive vapor phase
3. Inconsistent delivery of liquid nitrogen
4. Variation in cool-down time from one point to another

Keeping cryogenics cold

Minimizing heat transfer is the primary challenge in the efficient and cost-effective transfer of cryogenics. All liquids seek an equilibrium with surrounding temperatures. Thus, a cryogen such as liquid nitrogen at -320°F seeks to reach an equilibrium with the air surrounding the transfer pipe. Heat is transferred in the following ways:

Conduction — transfer of heat through the motion of molecules in a solid (heat a spoon on one end and the other end will eventually get hot)

Convection — transfer of heat through molecules in gas (if the burner on a stove is warm, the heat can be felt by placing your hand close to it)

Radiation — transfer of heat through electromagnetic waves (step out of the shade into the sunshine and immediately feel the sun's radiant heat)

What You Need To Know About Nitrogen Piping

Traditional Cryogenic Fluid Transfer Piping

For decades, the accepted method of insulating cryogenic transfer pipe (typically copper) was to use foam insulation covered by a protective polyvinyl chloride layer. This type of insulation is inexpensive and works well when new, providing typical heat transfer rates above 20 BTU/hr/ft at LN₂ temperatures. However, its performance deteriorates rapidly within about five years, and this method becomes less and less effective in preventing vaporization of the liquid as the product ages.

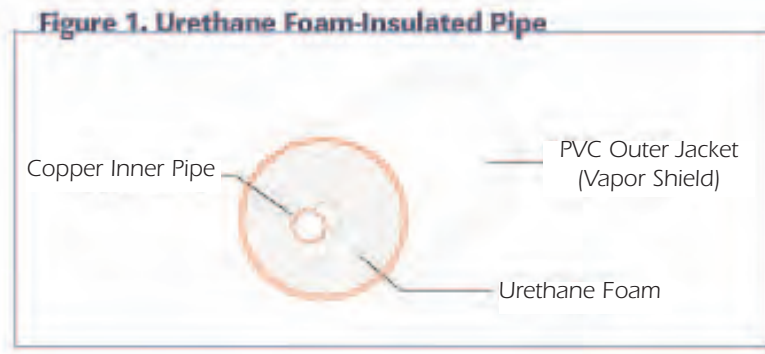

If you are using liquid nitrogen (LN₂) in your processing operation and your transfer lines are more than 20 years old, you might be losing money every day. However, you probably won't see a puddle on the floor to warn you that something is amiss. Instead, what typically happens is that you will gradually use more and more LN₂ with each passing year — so gradually, in fact, that you probably won't even notice the increase.

Estimated Heat Leak Performance - 1 in. IPS Foam Insulated

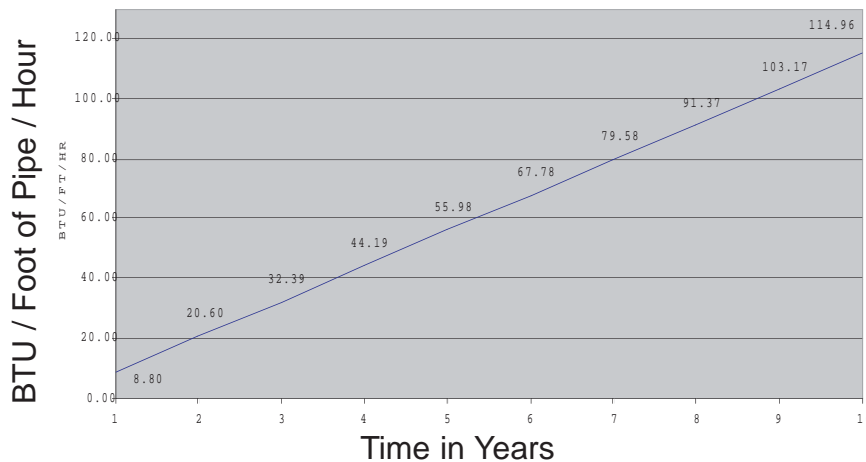

What You Need To Know About Nitrogen Piping

Vacuum Jacketed Piping

The technology in transfer piping for LN₂ and other cryogenic fluids has made substantial advances since the early 1990s. Not only are today's transfer lines better insulated to minimize the loss of LN₂ through evaporation, but they are also easier to install and are virtually maintenance-free.

Two types of vacuum jacketed piping (VJP) systems (also referred to as vacuum insulated) — rigid and flexible — are available for process plant installations where long runs of piping are required to transfer LN₂ from a bulk storage vessel at the back of the plant to one or several use points.

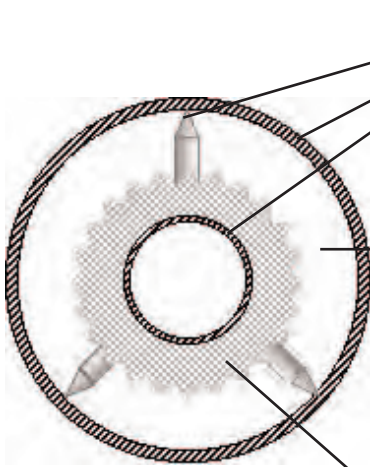

Conduction - Technifab vacuum jacketed piping technology reduces conduction by employing low conductivity radial supports to prevent the inner pipe from touching the outer pipe.

Convection - is prevented by removing the gas molecules from the space between the inner and the outer pipe. Technifab's evacuation process provides the best possible vacuum levels.

Radiation - the inner pipe is wrapped with multiple layers of reflective as well as spacer material to reduce radiation.



The inner pipe which carries the cryogenic liquid is wrapped with multiple layers of super-insulation. The insulation consists of alternating layers of radiant heat barrier material and non-conductive spacer material. The space between the two lines is evacuated.

What You Need To Know About Nitrogen Piping

Rigid Vacuum Jacketed Pipe

With rigid VJP, each pipe section is constructed of a rigid inner and outer pipe (see Figure 2). The inner pipe, which carries the cryogenic liquid, is wrapped with multiple layers of super-insulation consisting of alternating layers of a radiant heat barrier material and a non-conductive spacer material. The space between the two lines is evacuated to the highest industry standards. The vacuum annulus contains getter materials to adsorb out-gassed molecules, thereby further improving the vacuum.

Rigid VJP is easier to install than foam insulated copper pipe and is designed to be maintenance-free for a minimum of 10 years, with no deterioration of the system performance over that period. Pipe sections are joined with vacuum-insulated bayonet connectors that provide frost-free connections. Bayonet fittings are used to simplify installation while maintaining the integrity of the insulating system.

The thermal barrier between the inner and outer lines is so effective that the outer pipe remains at room temperature even while -320°F liquid nitrogen is flowing through the inner line. For ease and speed of installation, rigid VJP can also be routed across the plant roof and can be exposed to direct sunlight without affecting the system's performance.

This type of system is typically used in food plants that use cryogenic liquids in their processing operations, pharmaceutical plants that require long supply runs of cryogenic liquid from the bulk storage tank to multiple use points, and processing facilities with long exterior pipe runs that are exposed to outdoor elements.



Techniguard vacuum jacketed pipe installed across a plant roof.

What You Need To Know About Nitrogen Piping

Bendable Vacuum Jacketed Pipe

Bendable VJP is constructed of convoluted inner and outer tubing. The inner tube, which serves as the LN₂ carrier, is insulated with alternating layers of reflective foil and non-conductive spacer material and is loaded into the outer tube, which contains the vacuum jacket. The flexible system uses the same bayonet connectors as the rigid piping systems.

Bendable piping has several advantages over the more traditional rigid VJP, all of which translate into cost savings and improved system options for growing plant operations. For example, the flexibility of the pipe reduces the necessity for precise system layout measurements and allows much or all of a system to be reused if use-point locations are changed due to changes in the plant layout. You can also add to the existing system without major rework expenses, and the bayonet connections are easily taken apart and reassembled. Additionally, bendable pipe systems are coiled and crated for shipment by motor or air freight, which eliminates the need for expensive dedicated trucks.

Bendable VJP is often used in startup operations where cost is an important consideration, as well as in operations where substantial plant growth is anticipated. Other applications include laboratories where future rerouting of piping system may be necessary, new product launch facilities that need to be brought online quickly, and the replacement of old, inefficient (leaky) LN₂ piping.

Bayonet Connections

Vacuum jacketed pipe with bayonet connections has demonstrated higher thermal efficiency versus vacuum jacketed pipe with foam-insulated joints.



Bendable vacuum jacketed pipe sections are quickly and easily assembled with bayonet connections and provide high thermal efficiency.

What You Need To Know About Nitrogen Piping

Your Profits can Evaporate with Un-insulated Pipe All it takes is a two-foot section of bare pipe

One might ask, "How much harm can a small section of poorly insulated or un-insulated pipe cause when the major portion of the system is vacuum insulated?" The answer is, "plenty of harm." The loss is not immediately visible nor is it significant for one day, but over time that loss can add up to thousands of dollars. (see Product Loss Comparison chart).

Due to the extreme temperature difference between liquid nitrogen and ambient air a large amount of heat will transfer through a very short section of un-insulated or poorly-insulated pipe or component very quickly.

Even a short section of exposed pipe can have a substantial impact on the entire system. Increased heat leak at any point in the system can cause two-phase fluid that increases pressure drop, causing irregular flow of liquid, which reduces the overall flow rate. Two-phase flow will create significantly higher pressure drops through the pipe system, irregular liquid delivery, results in warmer liquid at the cryogen use point and shortens the life of valve seats and other components within the system. Let's look at two examples:

Example A:

Let's assume we have a 100-foot run of vacuum jacketed pipe (VJP) with a 2-foot connection of foam-insulated pipe.

Vacuum Jacketed Pipe (1.0 in. dia.) typically transfers about .47 BTU/hr/ft
Total Heat Leak of the 100-ft run of VJP is $100 \times .47 = 47$ BTU/hr

Foam Insulated Copper Pipe typically transfers about 20 BTU/hr /ft
Heat leak of a 2-ft section of foam insulated copper pipe is $2 \times 20 = 40$ BTU/hr

continued on the next page:

What You Need To Know About Nitrogen Piping

Result

The 2-foot section of foam insulated copper pipe is responsible for 40 / (40+47) 46% of the total heat transferred into the pipe.

Total heat leak for the 100-foot run of fully vacuum insulated pipe is 47 BTU / Hour

The heat leak for the 100-foot vjp system plus the 2-foot foam insulated copper pipe is 87 BTU/hr

Example B:

The consequences escalate with bare, uninsulated pipe.

Heat leak of a 2-foot section of bare copper pipe is $2 \times 400 = 800$ BTU/hr

Result

The two-foot section of bare copper pipe is therefore responsible for 800 / (800+47) 95% of the total heat transferred into the pipe.

Needless to say that with energy costs rising, any new or upgraded liquid nitrogen system should be designed with a complete system perspective in mind in order to obtain the most efficient system for optimum performance and lowest maintenance cost over the life of the system.

To request a custom evaluation of your current system and a payback analysis on a Technifab vacuum jacketed system for the transfer of liquid nitrogen, call Technifab at 1-812-442-0520 or email sales@technifab.com.

What You Need To Know About Nitrogen Piping

Getting the Return on Your Investment

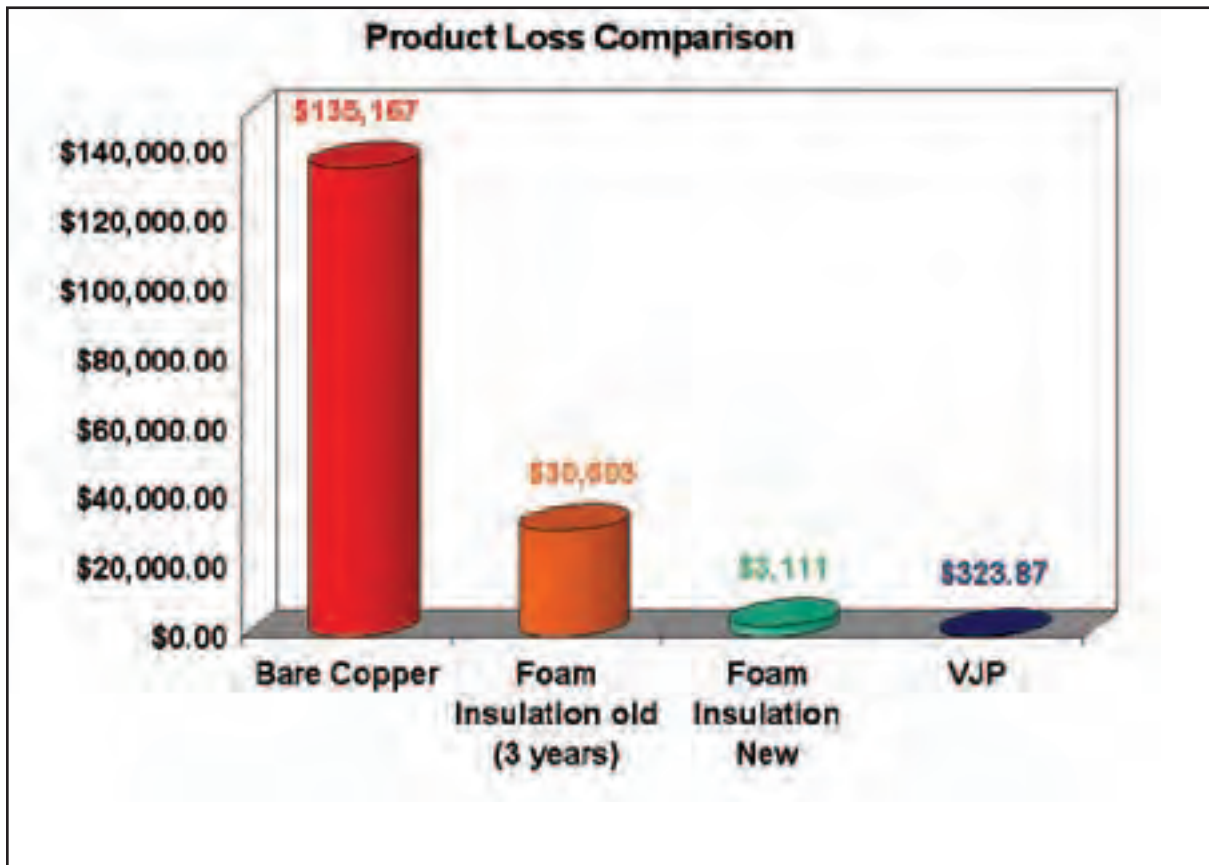

Although the initial purchase price of a VJP system can be higher than for non-vacuum systems, VJP systems typically provide a quick payback by reducing operating costs. These systems can significantly minimize the liquid losses caused by heat leaks, provide a longer life cycle than conventional foam-insulated copper piping, and do not decrease in performance over time. They can also increase production efficiency by improving the quality of the LN₂ flowing through the lines (delivering colder LN₂ to the use point), and can improve process safety by eliminating frosty and dripping conditions.

Ask us for a Cost / Thermal Performance Analysis for your plant

What You Need To Know About Nitrogen Piping

Advantages of Vacuum Jacketed Pipe

- Significant reduction in loss of liquid cryogen caused by heat leaks.
- Quick return on investment in new vacuum jacketed pipe installation.
- Virtually no decrease in thermal performance of vacuum jacketed pipe over 10 years.
- The Technifab rigid vacuum jacketed pipe system is maintenance free for a minimum of ten years.
- Longest life cycle backed by a 10-year warranty.
- Increase in freezing capacity due to improved quality of liquid nitrogen.
- Consistent delivery of liquid nitrogen at the use points due to reduction of vapor content.
- Improved process safety due to elimination of frosty and dripping conditions.

What You Need To Know About Nitrogen Piping

What Technifab offers you

- A 10-year warranty on all Techniguard™ rigid vacuum jacketed pipe.
- On-site measurements anywhere in North America.
- Most efficient layout of the vacuum jacketed pipe system required for your application.
- Detailed proposal describing every component of the vacuum jacketed pipe system being offered.
- Manufacturer's specifications of the system presented for your review.
- Isometric ACAD drawing showing every detail of the proposed system.
- A Heat Leak Guide which will show you liquid nitrogen losses of your current foam insulated copper pipe system.
- Break-even analysis showing you the anticipated return on investment and long-term financial benefits to your operation's bottom line.
- Cash flow analysis showing you the immediate effect the new system will have on your plant operation.

Ask us for a **Cost / Thermal Performance Analysis** for your plant
The break-even analysis shows you the anticipated ROI as well as the long-term financial advantages.

For a detailed cost/thermal performance analysis for your plant installation, please contact Technifab Ph: 812.442.0520 and ask for the sales department or send an email requesting a detailed presentation to: sales@technifab.com.